

# SERIES

# EKOCIKKI



**New indirect warm  
air heater for poultry.  
Ecological, economic,  
eco-friendly.**



**EKOCIKKI** responds to the growing breeders need to have air heating systems with clean air. The increased power (**130 kW**) compared to SUPERCIKKI and less need of ventilation to assure air renewal thanks to the indirect heat exchange technology allow to install less **EKOCIKKI** heaters with obvious **advantages from the point of view of efficiency and energy consumption**.

Totally sealed combustion chamber reduces excess of humidity in the environment, **eliminates completely the supply of CO<sub>2</sub>, CO and NO<sub>x</sub> resulting from the combustion residues**, reduces the need of ventilation and ensures a **healthy growth environment for animals**. The combustion chamber and smoke tubes of EKOCIKKI are entirely made of stainless steel AISI 430.

**EKOCIKKI** heater provides direct air distribution (does not require air ducts). It can be configured for external or internal installation and allows to mix the necessary amount of internal return air with fresh outside air.

**EKOCIKKI** can be installed outdoors without any additional protection saving precious inside spaces for breeding. The combustion is made with a blown burner: **extremely reliable technology** that ensures a stable operation of the heater even in the most demanding conditions. The adoption of this technology allows the use of **gas and oil** burners (no need to modify the product) and to have prompt competent assistance.

## MAIN COMPONENTS

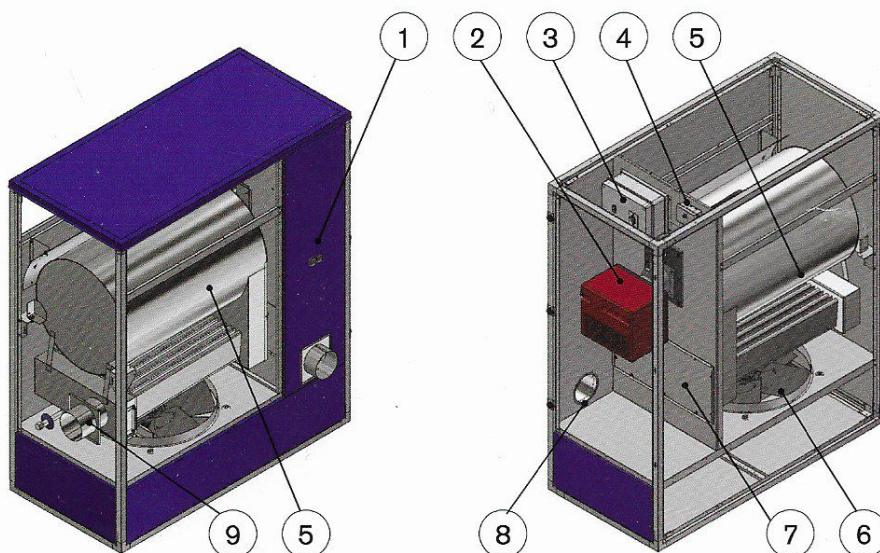

1. Alarms inspection panel.
2. Blown burner.
3. Electric board.
4. Safety thermostat.
5. Heat exchanger.
6. Axial fan.
7. Heat exchanger inspection door.
8. Combstion air intake.
9. Flue gas connection.

## EKOCIKKI: outside and inside installation example

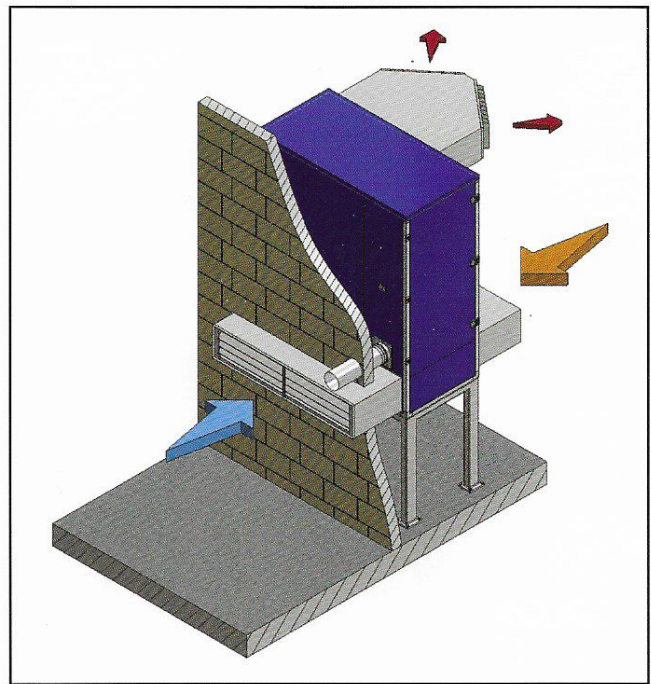
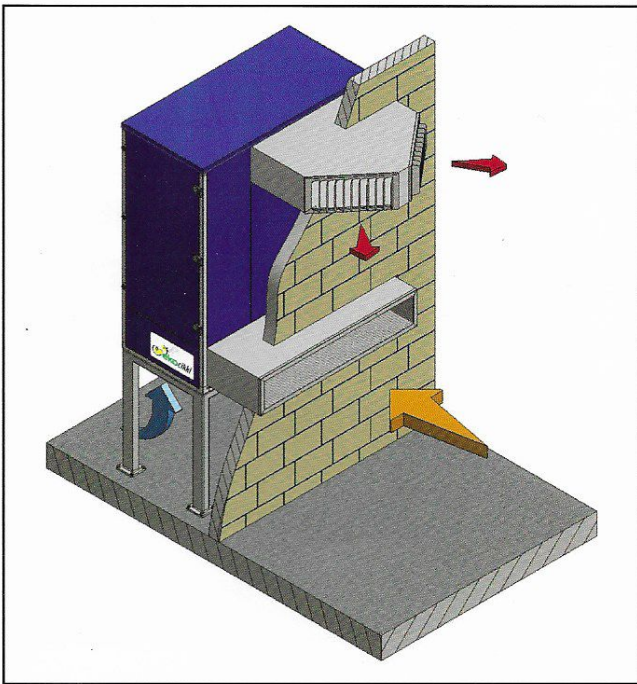

## DIMENSIONS

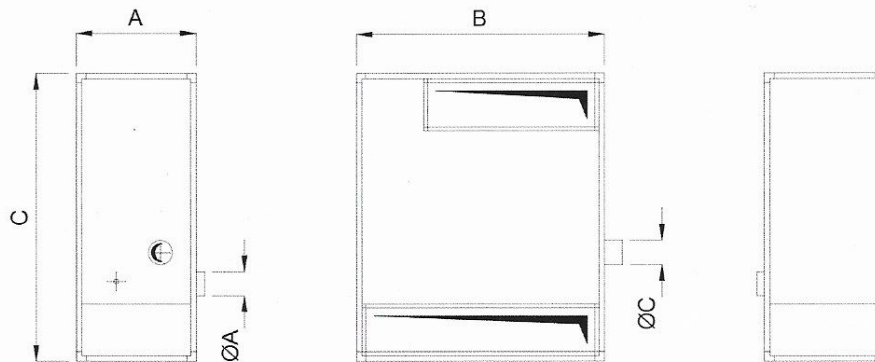

Width (A), mm	Length (B), mm	Height (C), mm	ØA, mm	ØC, mm	Weight, kg
750	1550	1800	150	150	290

## TECHNICAL SPECIFICATIONS **EKOCIKKI** SERIES

Model	Unit	EKOCIKKI 130
Heating capacity input	kW	130,0
	kcal/h	111.800
Heating capacity output	kW	120,0
	kcal/h	103.200
Efficiency	%	92,0
Nominal air flow	m <sup>3</sup> /h	8.000
Air temperature deviation (ΔT)	K	45,0
Electrical power	kW	1,0
Electrical supply	three-phase	400V - 50Hz 3N

⚠ On request INOX casing and customized technical features are available.

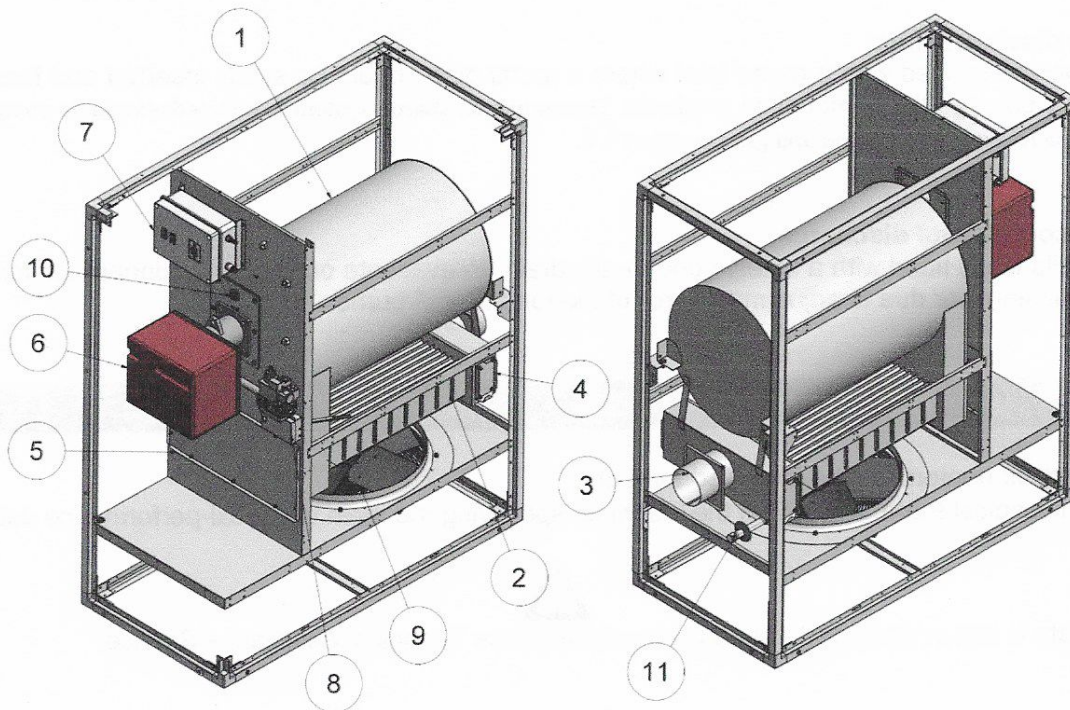

1. Combustion chamber
2. Smoke pipes
3. Chimney connector
4. Rear flue manifold inspection door
5. Front flue ventor inspection door
6. Blown burner
7. Electrical panel
8. Thermostats unit
9. Helical fan
10. Flame eyehole
11. Safety condensate discharge connector

The control of the start and stop of the fan unit is managed by the timer and the thermostat with parallel operation.

#### Fan start:

A timer gives the start consent to the fan unit after 60 seconds from the closing of the contact of the room thermostat. There is also a calibrated thermostat, which operates in parallel at 50°C, with the sensitive element placed on the flow of the hot air.

#### Fan shutdown:

A timer gives the stop consent to the fan unit after 180 seconds from the opening of the contact of the room thermostat. There is also a calibrated thermostat, which operates in parallel at 50°C, with the sensitive element placed on the flow of the hot air.

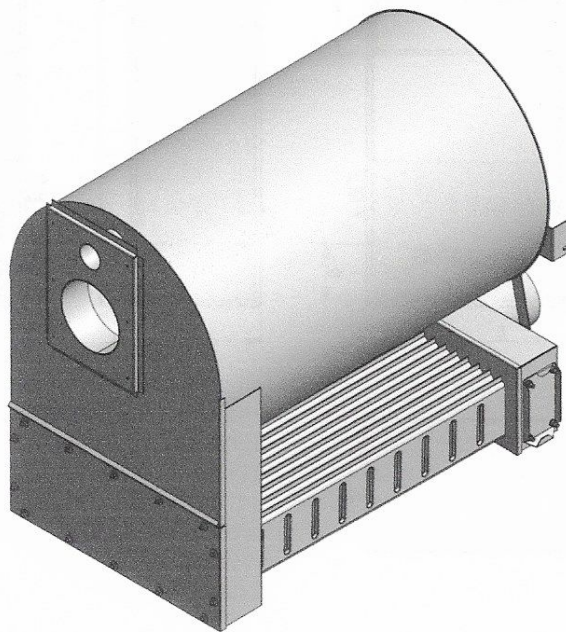
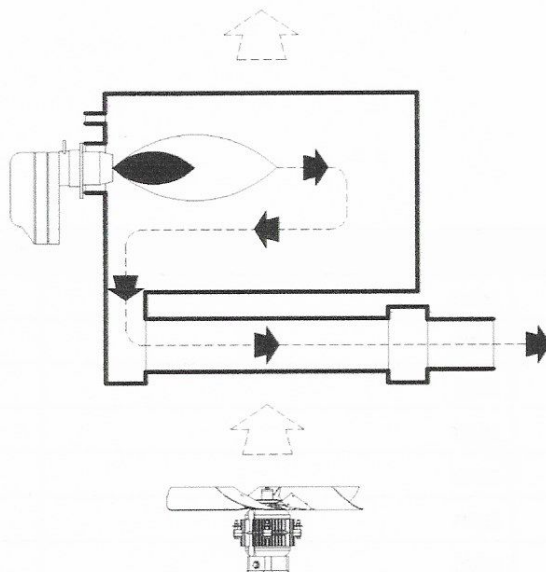
**Axonometric image heat exchanger:****Operating diagram:****Combustion products:**

- perform an inversion in the combustion chamber
- are routed to the first exhaust manifold (front manifold) and are channelled in the exchange elements (smoke pipes);
- arrive in the second exhaust manifold (rear collector) and then they are discharged trough the circular connector

**The air to be treated:**

- with counter-current flow, it first hits the tube bundle and, then, the combustion chamber

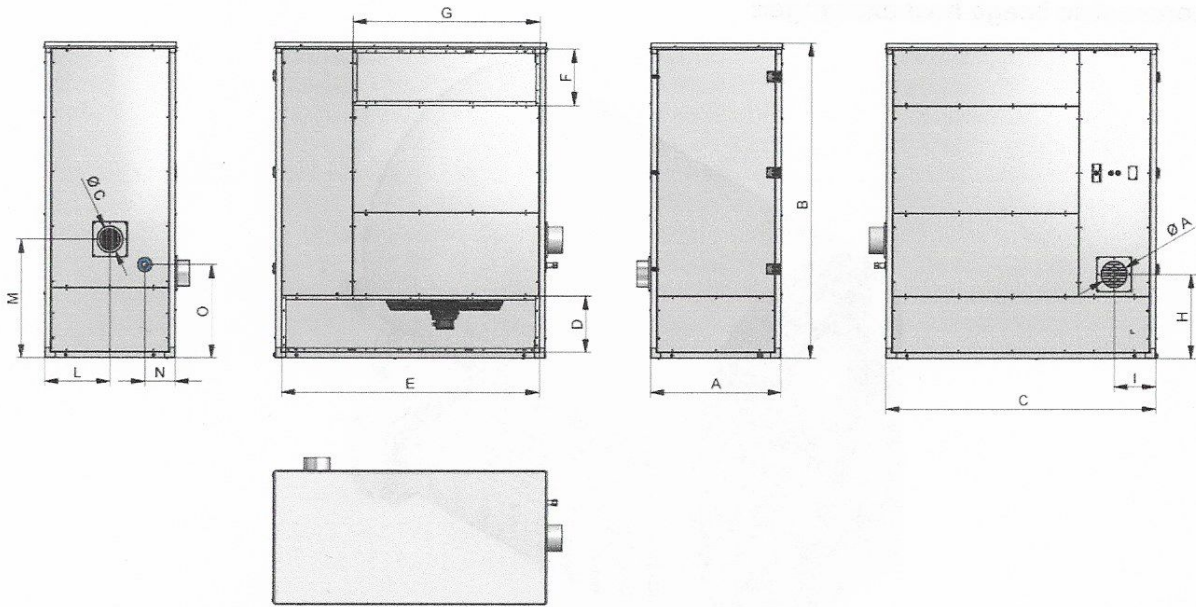

TYPE		1
A	mm	770
B	mm	1,800
C	mm	1,550
D	mm	320
E	mm	1,480
F	mm	320
G	mm	1,070
H	mm	480
I	mm	240
L	mm	375
M	mm	675
N	mm	175
O	mm	530
ØC	mm	150
ØA	mm	150
<b>NET WEIGHT</b>	kg	320

TYPE		1
HEAT OUTPUT <sup>1</sup> (burned)	KW	130
	Kcal/h	111,800
COMBUSTION EFFICIENCY	%	92
THERMAL POWER <sup>1</sup> (net)	KW	120
	Kcal/h	103,200
BACKPRESSURE IN COMBUSTION CHAMBER	mbar	1
NET FUMES TEMPERATURE <sup>2</sup>	°K	~ 175
FUMES MASS FLOW WITH METHANE GAS G20	Kg/h	~ 200
AIR FLOW	m <sup>3</sup> /h	8,000
AIR THERMAL GRADIENT (ΔT)	°K	44
INSTANT FUEL CONSUMPTION <sup>3</sup>		
G20 methane gas	Nm <sup>3</sup> /h	13.8
Methane gas G25:	Nm <sup>3</sup> /h	16.0
Propane gas G31:	Nm <sup>3</sup> /h	5.3
	Kg/h	10.1
	l/h	19.8
G30 butane gas:	Nm <sup>3</sup> /h	4.0
	Kg/h	10.2
	l/h	17.8
Fuel:	Kg/h	11.0
GENERAL POWER SUPPLY	THREE-PHASE	400V ~ 50Hz
HELICAL ELECTRIC FAN MOTOR		
Electric power	W	936
Max current	A	2.8
Class of insulation		F
Degree of protection	IP	55
SAFETY THERMOSTAT WITH AUTOMATIC RESET		
Brand IMIT	mod	TR2
Adjusting range	°C	0÷90
Set-point adjusted at the factory	°C	85
SAFETY THERMOSTAT WITH MANUAL RESET		
Brand IMIT	mod	LS1
Set-point adjusted and sealed at the factory	°C	100
FAN CONTROL THERMOSTAT		
Brand IMIT	mod	TR2
Adjusting range	°C	0÷60
Set-point adjusted at the factory	°C	50
OPERATIONAL LIMITS		
Temperature	°C	-15/+35
Relative humidity at 30° non-condensing	Rh	90
SOUND PRESSURE <sup>4</sup>	dB(A)	68
LAUNCH DISTANCE <sup>5</sup>	m	45

1) Referred to a lower heating power (Hi)

2) Referred to combustion air temperature +15°C

3) G20 methane gas Hi = 34.02 MJ/Nm<sup>3</sup>  
Methane gas G25: Hi = 29.25 MJ/Nm<sup>3</sup>  
Propane gas G31: Hi = 88.00 MJ/Nm<sup>3</sup>=11,070 Kcal/kg=5,635 Kcal/l  
G30 butane gas: Hi = 116.09 MJ/Nm<sup>3</sup>=10,905 Kcal/kg=6,286 Kcal/l  
Fuel oil: Hi = 10,200 Kcal/kg

4) In free field at 6 meters away

5) measured at +15°C at a residual speed of 0.1 m/s